

OXFORD

INTERNATIONAL
AQA EXAMINATIONS

INTERNATIONAL A-LEVEL PHYSICS

PH05

Unit 5 Physics in practice

Mark scheme

January 2023

Version: 1.0 Final



Mark schemes are prepared by the Lead Assessment Writer and considered, together with the relevant questions, by a panel of subject teachers. This mark scheme includes any amendments made at the standardisation events which all associates participate in and is the scheme which was used by them in this examination. The standardisation process ensures that the mark scheme covers the students' responses to questions and that every associate understands and applies it in the same correct way. As preparation for standardisation each associate analyses a number of students' scripts. Alternative answers not already covered by the mark scheme are discussed and legislated for. If, after the standardisation process, associates encounter unusual answers which have not been raised they are required to refer these to the Lead Examiner.

It must be stressed that a mark scheme is a working document, in many cases further developed and expanded on the basis of students' reactions to a particular paper. Assumptions about future mark schemes on the basis of one year's document should be avoided; whilst the guiding principles of assessment remain constant, details will change, depending on the content of a particular examination paper.

Further copies of this mark scheme are available from oxfordaqaexams.org.uk

Copyright information

OxfordAQA retains the copyright on all its publications. However, registered schools/colleges for OxfordAQA are permitted to copy material from this booklet for their own internal use, with the following important exception: OxfordAQA cannot give permission to schools/colleges to photocopy any material that is acknowledged to a third party even for internal use within the centre.

Copyright © 2023 Oxford International AQA Examinations and its licensors. All rights reserved.

Level of response marking instructions

Level of response mark schemes are broken down into levels, each of which has a descriptor. The descriptor for the level shows the average performance for the level. There are marks in each level.

Before you apply the mark scheme to a student's answer read through the answer and annotate it (as instructed) to show the qualities that are being looked for. You can then apply the mark scheme.

Step 1 Determine a level

Start at the lowest level of the mark scheme and use it as a ladder to see whether the answer meets the descriptor for that level. The descriptor for the level indicates the different qualities that might be seen in the student's answer for that level. If it meets the lowest level then go to the next one and decide if it meets this level, and so on, until you have a match between the level descriptor and the answer. With practice and familiarity you will find that for better answers you will be able to quickly skip through the lower levels of the mark scheme.

When assigning a level you should look at the overall quality of the answer and not look to pick holes in small and specific parts of the answer where the student has not performed quite as well as the rest. If the answer covers different aspects of different levels of the mark scheme you should use a best fit approach for defining the level and then use the variability of the response to help decide the mark within the level, ie if the response is predominantly level 3 with a small amount of level 4 material it would be placed in level 3 but be awarded a mark near the top of the level because of the level 4 content.

Step 2 Determine a mark

Once you have assigned a level you need to decide on the mark. The descriptors on how to allocate marks can help with this. The exemplar materials used during standardisation will help. There will be an answer in the standardising materials which will correspond with each level of the mark scheme. This answer will have been awarded a mark by the Lead Examiner. You can compare the student's answer with the example to determine if it is the same standard, better or worse than the example. You can then use this to allocate a mark for the answer based on the Lead Examiner's mark on the example.

You may well need to read back through the answer as you apply the mark scheme to clarify points and assure yourself that the level and the mark are appropriate.

Indicative content in the mark scheme is provided as a guide for examiners. It is not intended to be exhaustive and you must credit other valid points. Students do not have to cover all of the points mentioned in the Indicative content to reach the highest level of the mark scheme.

An answer which contains nothing of relevance to the question must be awarded no marks.

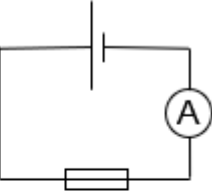
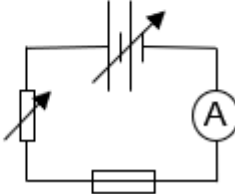
Question	Answers	Additional comments/Guidelines	Mark	AO
01.1	<p>A working series circuit including fuse wire, ammeter and cell/battery/power supply ✓</p> <p>The working series circuit has means of controlling the current AND the voltage source is not just a cell ✓</p>	<p>MP1 </p> <p>MP2 </p> <p>Control may be by variable resistor, potentiometer or variable voltage supply</p> <p>Ignore presence of voltmeter unless it affects the operation of the circuit</p>	2	<p>1 × AO3</p> <p>1 × AO4</p>

Question	Answers	Additional comments/Guidelines	Mark	AO
01.2	Max 5 from <ul style="list-style-type: none"> • Use a micrometer screw gauge/digital micrometer to measure the wire diameters. • Measure diameter in more than one direction at more than one position • Start with resistor on maximum/variable power supply on minimum • Increase the current slowly and record the maximum value before the wire breaks. • Take repeat readings and calculate mean values for each diameter and each current. • Use a log-log plot and obtain gradient of 1.5, or a plot of I against $D^{1.5}$ to verify the formula. ✓✓✓✓✓		5	AO4
Total			7	

Question	Answers	Additional comments/Guidelines	Mark	AO
02.1	Thin (metal) walls OR high thermal conductivity and valid explanation eg reference to $\dot{Q} = \frac{kA\Delta\theta}{l}$ ✓	Accept surface condition such as rough/black with suitable explanation Accept shape of container with large exposed surface area of liquid/not having a lid to promote evaporation	1	AO3

Question	Answers	Additional comments/Guidelines	Mark	AO
02.2	Well drawn smooth curve passing through or near to all the plotted points with an even scatter of the points about the line ✓	'Near' means within one grid square	1	AO3

Question	Answers	Additional comments/Guidelines	Mark	AO
02.3	Read off temperatures from Figure 4 at $t = 0$ and $t = 300$ s ✓ Use $Q = mc\Delta\theta$ ✓	Allow both marks if candidates use c from 02.5 and actually perform the calculation Expect to see an answer of around 12 400 J	2	AO3

Question	Answers	Additional comments/Guidelines	Mark	AO
02.4	Well drawn tangent to the curve for $\theta = 45\text{ }^\circ\text{C}$ to create a large triangle ✓ Use of the tangent and an answer in the range 0.090–0.110 (K s^{-1}) ✓	At least 2 sf	2	AO2
Question	Answers	Additional comments/Guidelines	Mark	AO
02.5	Use of $P = mc \frac{\Delta\theta}{\Delta t}$ ✓ Answer in the range 2000–2300 ($\text{J kg}^{-1} \text{K}^1$) ✓	2 or 3 sf only	2	AO3
Total			8	

Question	Answers	Additional comments/Guidelines	Mark	AO
03.1	$(1/44) \times 100 = 2(.3)(\%) \checkmark$	Accept $2 \times$ this answer for candidate who uses a ± 1 mm at each end of the measurement No sf penalty	1	AO2

Question	Answers	Additional comments/Guidelines	Mark	AO
03.2	% uncertainty = $2 \times 2.3 \checkmark$ Absolute uncertainty = 0.88 or 0.89 (mm ²) \checkmark	Allow ecf from 03.1 No sf penalty Expect a range depending on answer to 03.1	2	AO2

Question	Answers	Additional comments/Guidelines	Mark	AO
03.3	Evidence that at least two measurements were taken \checkmark Answer in the range 7.5–7.8 (mm) \checkmark	2 sf only	2	AO3

Question	Answers	Additional comments/Guidelines	Mark	AO
03.4	$(5.4 \text{ to } 6.0) \times 10^{-7} \checkmark$	2 sf but condone 3 sf	1	AO2

Question	Answers	Additional comments/Guidelines	Mark	AO
03.5	2 × answer to 03.2 seen OR evaluates $03.3^2 - 4.4^2 \checkmark$ Uncertainty in $r = 0.3\%$ seen \checkmark % uncertainty calculation leading to a consistent answer \checkmark	4.7(%) expected 1 or 2 sf only	3	1 × AO2 2 × AO3

Question	Answers	Additional comments/Guidelines	Mark	AO
03.6	Idea that (the absolute uncertainty in measuring D is unchanged and so) the % uncertainty is reduced as $D > d \checkmark$	Accept difficulty of counting rings on Figure 4	1	AO4
Total			10	

Question	Answers	Additional comments/Guidelines	Mark	AO
04.1	Idea that it is the horizontal component of the tension in the string OR resultant of tension in the string and the weight of the mass ✓	Do not accept 'gravity' for 'weight'	1	AO3

Question	Answers	Additional comments/Guidelines	Mark	AO
04.2	Sensible scale chosen on both axes ✓ (0.689, 2.79) plotted accurately ✓ (0.992, 4.04) plotted accurately ✓ Well drawn straight line of best fit ✓	The line of best fit should follow the trend of the points with an even scatter of points on either side of the line. Do not award MP1, MP2 or MP3 if scale not marked.	4	AO3

Question	Answers	Additional comments/Guidelines	Mark	AO
04.3	Gradient found from a large triangle ✓ Answer in the range 3.9–4.2 ✓	Ignore unit No sf penalty	2	AO3

Question	Answers	Additional comments/Guidelines	Mark	AO
04.4	Answer in the range 9.40–10.1(12) ✓ Quoted to 2 or 3 sf ✓		2	AO3

Question	Answers	Additional comments/Guidelines	Mark	AO
04.5	Relevant calculation ✓ Valid comparison with stated value leading to answer that the idea is supported. ✓	E.g Calculates a value for $\frac{4\pi^2}{k}$ for a point on the line Correctly calculates two values for different points and says that they are (approximately) the same Candidates can gain both marks for finding the equation of the line and showing that the intercept is approximately zero or for using a similar triangle method of finding the intercept and showing that it is approximately zero	2	AO3
Total			11	

Question	Answers	Additional comments/Guidelines	Mark	AO
05.1	Use of $P = VI$ ✓ Use of efficiency = $\frac{\text{useful output power}}{\text{input power}}$ ✓ 55(.1) (A) ✓		3	1 × AO1 1 × AO2 1 × AO3

Question	Answers	Additional comments/Guidelines	Mark	AO
05.2	Evidence of use of $\omega = 2\pi f$ ✓ Angular speed of A is 262 (rad s ⁻¹) OR finds ratio of the two angular speeds ✓ 2500 (revolutions per minute) ✓	Look for $\frac{480}{262}$ but condone wrong value of ω_A for MP2	3	1 × AO1 1 × AO2 1 × AO3

Question	Answers	Additional comments/Guidelines	Mark	AO
05.3	Use of power = torque × ω ✓ Use of torque = $0.06 \times F$ ✓ 32.3 (N) ✓	Allow approach using power = force x speed In MP2 condone use of diameter	3	1 × AO1 2 × AO2

Question	Answers	Additional comments/Guidelines	Mark	AO
05.4	Use of $\sigma = \frac{F}{A}$ and $\varepsilon = \frac{\Delta l}{l}$ ✓ Use of $E = \frac{\sigma}{\varepsilon}$ ✓ $4.0(4) \times 10^{-5} \text{ m}^2$ ✓	Award both MP1 and MP2 for candidates who use $E = \frac{Fl}{\Delta l A}$ Penalise 1 sf answer	3	1 × AO1 2 × AO2

Question	Answers	Additional comments/Guidelines	Mark	AO
05.5	Effect on system ✓ ₁ Effect on performance ✓ ₂	Examples Lower pulley speed ✓ ₁ so lower voltage output ✓ ₂ Work done against friction ✓ ₁ so reduced power output ✓ ₂ Belt will wear ✓ ₁ with a consequence for maintenance or risk of failure ✓ ₂	2	AO4
Total			14	

Question	Answers	Additional comments/Guidelines	Mark	AO
06.1	States and uses $I = \sum mr^2$ (to find r) ✓ Evidence of $I = m\left(\frac{L}{2}\right)^2 + m\left(\frac{L}{2}\right)^2$ 1.86 (m) to at least 3 sf ✓	Condone $I = 2m\left(\frac{L}{2}\right)^2$ for MP2	3	1 × AO1 1 × AO2 1 × AO3

Question	Answers	Additional comments/Guidelines	Mark	AO
06.2	Effect ✓ ₁ consequence ✓ ₂	Examples: Speed at centre of motion very slow ✓ ₁ difficulty of judging when it passes a fiduciary ✓ ₂ idea that the motion may be damped ✓ ₁ not complete (half) an oscillation ✓ ₂	2	1 × AO2 1 × AO4

Question	Answers	Additional comments/Guidelines	Mark	AO
06.3	Evidence of use of $f = \frac{1}{T}$ and substitution in given equation ✓ 2.77×10^{-4} (N m rad ⁻¹) to at least 3 sf ✓		2	1 × AO1 1 × AO2

Question	Answers	Additional comments/Guidelines	Mark	AO
06.4	$F = \frac{GMm}{r^2}$ or $T = FL$ seen ✓ Use of both equations to give $T = \frac{GMmL}{d^2}$ ✓	Condone alternative unambiguous symbols for r and L	2	1 × AO2 1 × AO3
Question	Answers	Additional comments/Guidelines	Mark	AO
06.5	Uses $T = k \alpha$ and correct substitution ✓ 6.02×10^{-11} to at least 2 sf ($\text{N m}^2 \text{ kg}^{-2}$) ✓	Calculator value is $6.0155102 \times 10^{-11}$	2	1 × AO1 1 × AO2
Question	Answers	Additional comments/Guidelines	Mark	AO
06.6	Uses $mg = \frac{GMm}{r^2}$ ✓ Uses $\rho = \frac{M}{\frac{4}{3}\pi r^3}$ ✓ $6110 (\text{kg m}^{-3})$ ✓	Accept value based on candidate's value of G from 06.5	3	1 × AO1 2 × AO2
Total			14	

Question	Answers	Additional comments/Guidelines	Mark	AO
07.1	Reference to conservation of momentum ✓ Ions gain momentum to the right ✓ Idea that to conserve momentum, the drive must acquire equal and opposite momentum to the left OR links force to rate of change of momentum and links acceleration to force ✓	Alternative: Reference to Newton 3 ✓ Force on ions from the grid ✓ Therefore there is (an equal and opposite) force on the grid and links acceleration to force ✓	3	1 × AO1 1 × AO2 1 × AO3

Question	Answers	Additional comments/Guidelines	Mark	AO
07.2	Use of $E = eV$ or use of $E_k = \frac{1}{2}mv^2$ ✓ Use of both equations leading to an answer of $4.37 \times 10^4 \text{ (m s}^{-1}\text{)}$ to at least 3 sf ✓		2	1 × AO1 1 × AO2

Question	Answers	Additional comments/Guidelines	Mark	AO
07.3	$1.1(2) \times 10^{-6} \text{ (kg)}$ ✓		1	AO2

Question	Answers	Additional comments/Guidelines	Mark	AO
07.4	Mass of products < mass of plutonium-238 ✓ Energy released equivalent to mc^2 ✓	MP2 is contingent on MP1	2	1 × AO1 1 × AO2

Question	Answers	Additional comments/Guidelines	Mark	AO
07.5	Determines number of moles ✓ Multiplies number of moles by 6.02×10^{23} to give 1.97×10^{25} to 3 sf ✓	E.g. Converts to g and divides by 238 Do not condone PoT error in MP1	2	1 × AO1 1 × AO2

Question	Answers	Additional comments/Guidelines	Mark	AO
07.6	Uses λN ✓ Multiplies by $5.69 \times 1.6 \times 10^{-13}$ ✓ Multiplies by 0.068 ✓ To give 303 and comment that power is too low for the ion drive ✓	Look for 4.9×10^{15} (Bq) Look for 4460 (W) but condone power of ten error (ie accept 1.6×10^{-19}) for MP2 Using show that 2×10^{25} from 07.5 gives 310	4	1 × AO1 1 × AO2 2 × AO4

Question	Answers	Additional comments/Guidelines	Mark	AO
07.7	Makes relevant numerical comparison ✓ Leading to idea that the initial power output of Sr is approximately $0.8 \times$ initial power output of Pu ✓	Examples for MP1: <ul style="list-style-type: none"> • same mass so Sr has about $2.5 \times$ no of Pu atoms • decay constant $3 \times$ larger for Sr • so initial activity significantly larger by about 8 times initial activity of the other RTG If no other mark awarded accept idea that: Sr is a beta emitter so shielding requirements will be more stringent OR Sr will not last as long (since decay constant is larger) ✓	2	1 × AO2 1 × AO3
Total			16	